

Manual for the
turntable

THORENS model TD-150

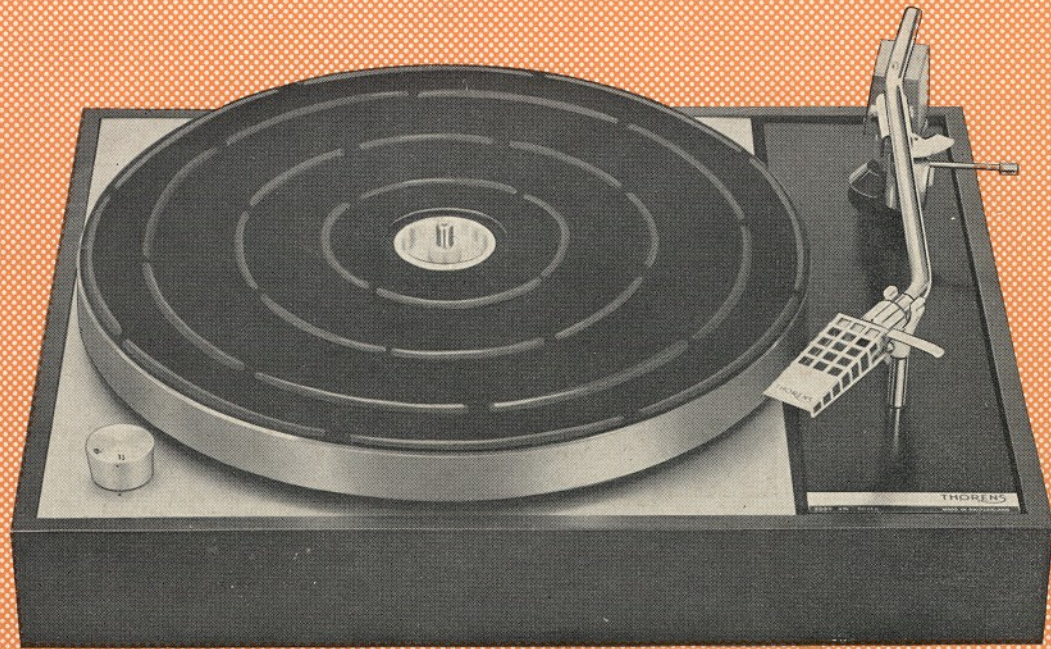

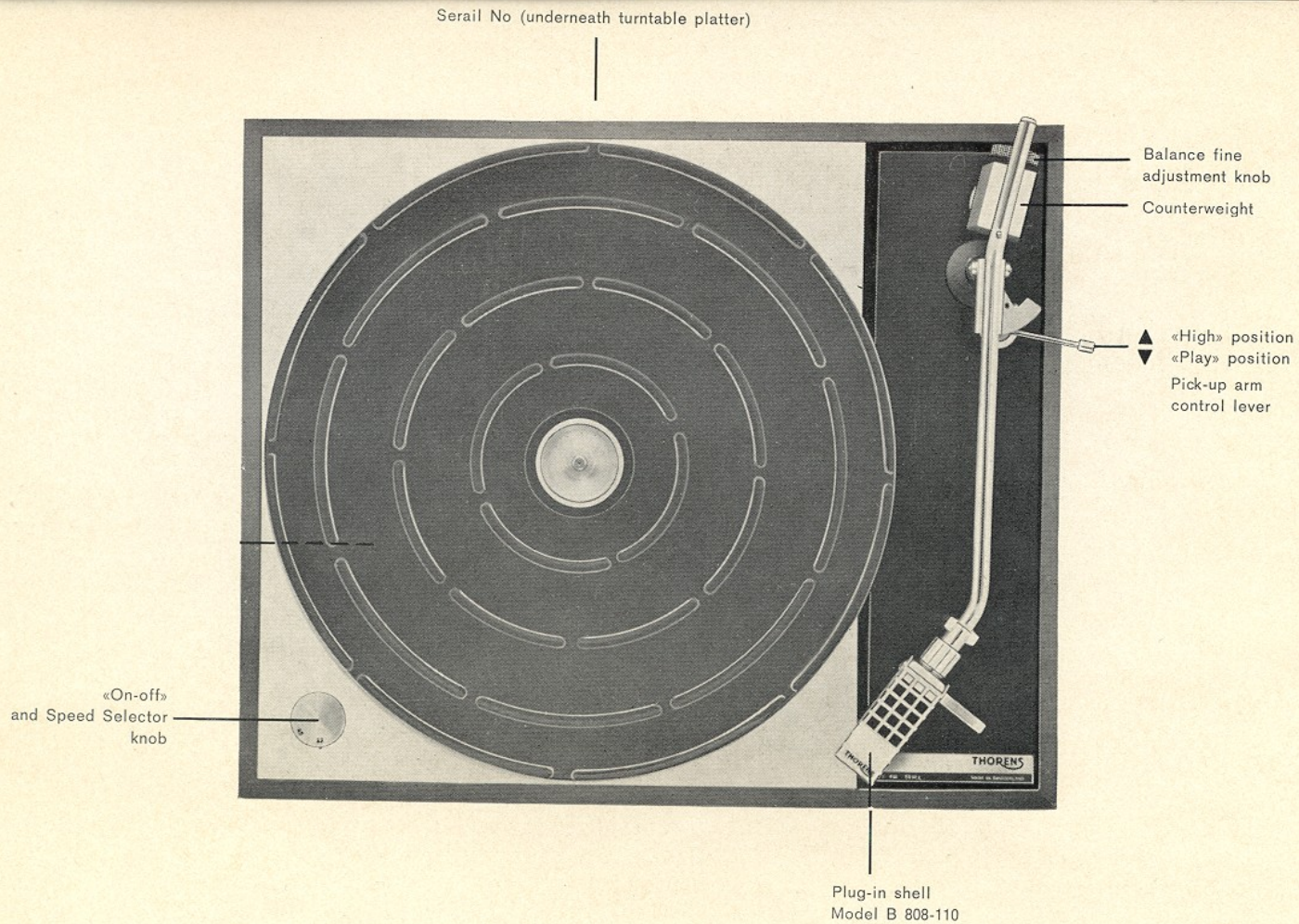

Fig. 1 TD-150 AB turntable with base and TP-13 pick-up arm.

Manual for the turntable

THORENS model **TD-150**

As the owner of a new THORENS TD-150, you have at your command a very high performance turntable. With the help of this booklet, you will find no problem when incorporating your TD-150 into the finest music system and under the most exacting conditions of installation.

Take a few minutes to carefully read every page. Examine the turntable as you read, making yourself familiar with all its features. You will then be able to immediately benefit by the outstanding performance of this instrument.

Designed by Swiss craftsmen, long established as world leaders in the manufacture of turntables, the TD-150, with a reasonable amount of care, will function perfectly indefinitely.

Model Code

The TD-150 turntable is generally delivered as an integrated turntable with pick-up arm and wooden base and designated then by **Model TD-150 AB**.

It is also available as follows:

TD-150 without pick-up arm and without base.

TD-150 A with pick-up arm, but without base.

TD-150 B without pick-up arm, but with base.

The majority of the instructions of this manual apply to all models but **the owner of a TD-150 AB turntable may consult only the paragraphs whose numbers are contained in a circle.**

I. Unpacking of the TD-150 AB and B turntables

- 1 You have already placed the carton top-side up and opened.
- 2 Take care that this manual, and template S 800-560 for models TD-150 and TD-150 A, are not misplaced.
- 3 Remove corrugated spacers A, B, C. Box D contains the accessories delivered with the unit.
- 4 Remove the four lateral corrugated spacers E.
- 5 Take the complete unit out of the box. The power cord and the pick-up leads are threaded through holes in spacers F and G.
- 6 Remove spacers F and G and take the outer turntable platter out of the box.

Leave the corrugated spacer H in position, between the inner turntable platter and the unit plate, until the TD-150 is completely installed for maximum protection of turntable main shaft and unit plate.

To remove corrugated spacer H, lift the inner turntable platter until the spacer may be carefully shifted from the unit plate.

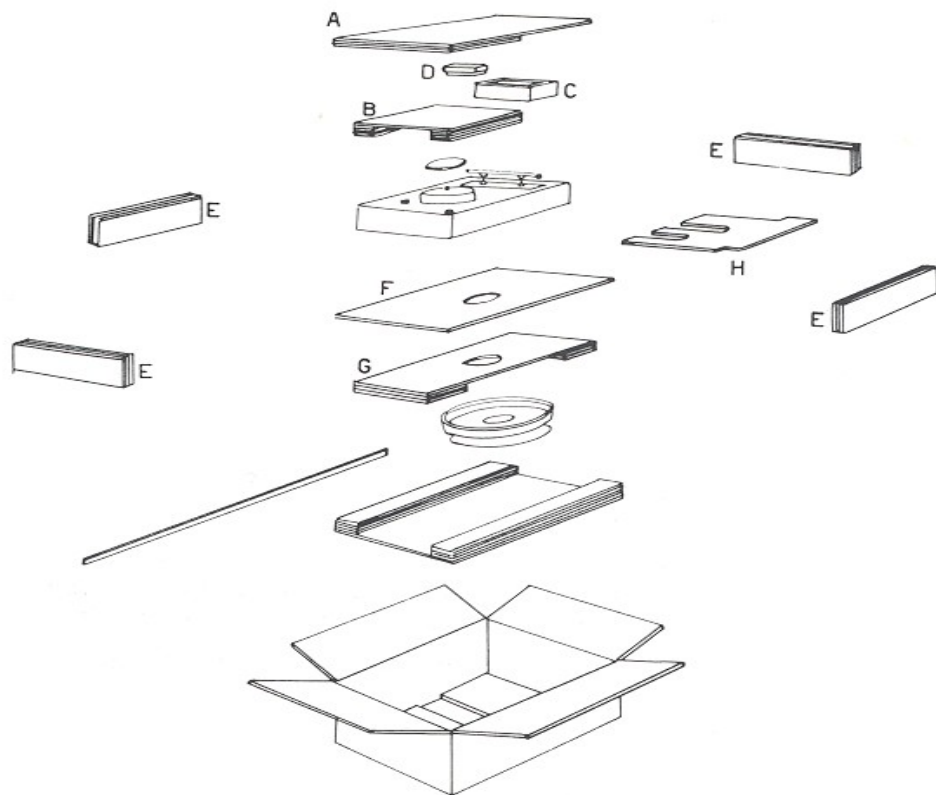

Fig. 2. Packing of the TD-150 AB and TD-150 B turntables.

II. Unpacking of the TD-150 and TD-150 A turntables

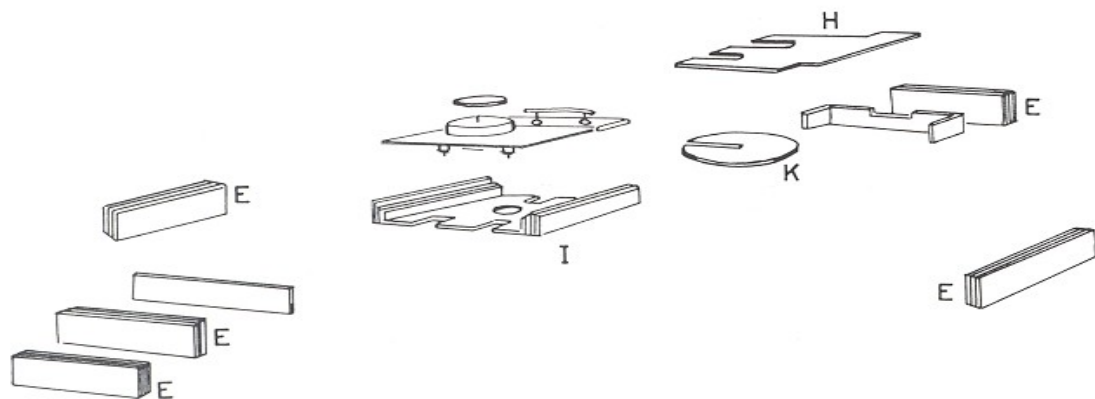

Fig. 3. Additional packing material for TD-150 A and TD-150 turntables.

Proceed in the same way as for Model TD-150 AB, points 1 to 4 (see page 2).

5. Take the complete unit, **with** corrugated spacer I as a provisional base, out of the box.
6. Remove spacers F and G and take the outer turntable platter out of the box (see Fig. 3).
7. **Corrugated spacers H and K should be left in position, between the inner turntable platter and the unit plate, until the TD-150 is completely installed for maximum protection of turntable main shaft and unit plate.**

To remove the spacers, lift the inner turntable platter until they may be shifted from the unit plate.

● Important notice

Save the complete packing for possible re-shipment. The TD-150 is a delicate instrument and would be seriously damaged if forwarded in an improvised packing. (Please see our warranty conditions on the last page of this booklet.)

III. Installation. Mounting the pick-up arm on a TD-150 or TD-150 B turntable

1. For the TD-150 B, with base, remove the bottom cover by taking out the four plastic feet.
2. Loosen, from the underside, the four screws fastening the wooden board (part S 801-578) to the metal frame of the unit.
3. Consult the instructions of the pick-up arm manufacturer and make use of the corresponding templates to mark the wooden board before drilling the necessary holes.
4. Install the pick-up arm on the wooden board and connect it according to the instructions of the manufacturer.
Pick-up arms with an output connector and an output cable may be connected directly to the amplifier, provided this cable has a **sufficient compliance**. **Any stiffening of the spring mount of the turntable through the pick-up leads should be avoided if best results are to be obtained.** If necessary, replace the output cable by more compliant leads and connect them to the unit connecting plate. See chapter VII (3) page 8. Pick-up arms without an output connector should be connected to the unit connecting plate.
5. Fasten the wooden board on the metal frame of the unit with the four screws.
6. A ground lead should connect the metal part of the arm to lug 1 (see Fig. 6).
7. Particularly heavy pick-up arms may require some adjustment of the two conical coil springs supporting the metal frame on which the wooden board is fastened. Adjust by turning the terminal nuts (part No. 200.50.11) on the threaded studs. The outer 12" turntable should be installed for this operation.

For pick-up arms with a very deep pivot post, it may become necessary to increase the height of the base on the TD-150 B turntable by cutting the bottom cover and making use of higher feet.

IV. Mounting the turntable on a panel

The TD-150 turntable should be mounted on a plywood mounting board of not less than $\frac{1}{2}$ " thickness and cut out according to template TD-560 provided. The mounting board should be as level as possible and its attachments very stable to minimize the transmission of floor vibrations.

Template No. TD-560

Two different modes of mounting the turntable on a panel are indicated on the template:

- A. With the unit plate lying on top of the panel and the brushed aluminium plate rising about $\frac{1}{16}$ " (2 mm) over the top surface of the panel.

Mark and cut the panel according to the dotted line A of the template.

- B. With the unit plate slightly recessed under the top surface of the panel.

Mark and cut the panel according to the plain line B of the template.

Fasten the four wooden supports C underneath the mounting panel, with screws or by gluing, in the position indicated on the template. Supports C are available as an accessory.

In both cases the unit plate should be fastened to the panel or to the wooden supports with 4 screws D.

● V. Power supply

As supplied for USA and Canada, the turntable motor is set for 60 cycle, 100 to 120 volt operation (see Fig. 5).

For other countries, unless differently specified when ordering, the motor is set for 50 cycle, 200 to 240 volt operation (see Fig. 4).

Fig. 4 Motor connections for 50 cycle 220 volt operation and 50 cycle 110 volt.

Adaptation from 200 to 100 volt operation requires only to short the 5,6 kohm 3 watt resistor by soldering a wire between lugs A and B (see Fig. 4).

Adaptation from 50 to 60 cycle operation requires the replacement of the whole motor with its integrated pulley:

Parts S 804-550 for 60 cycles
and S 800-550 for 50 cycles.

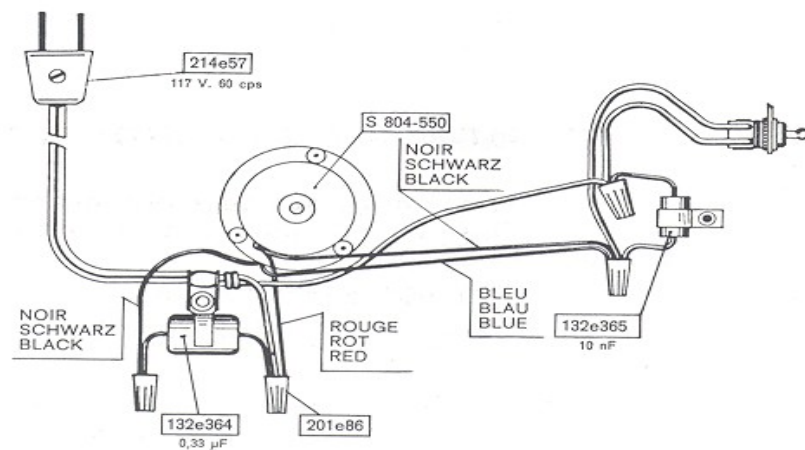
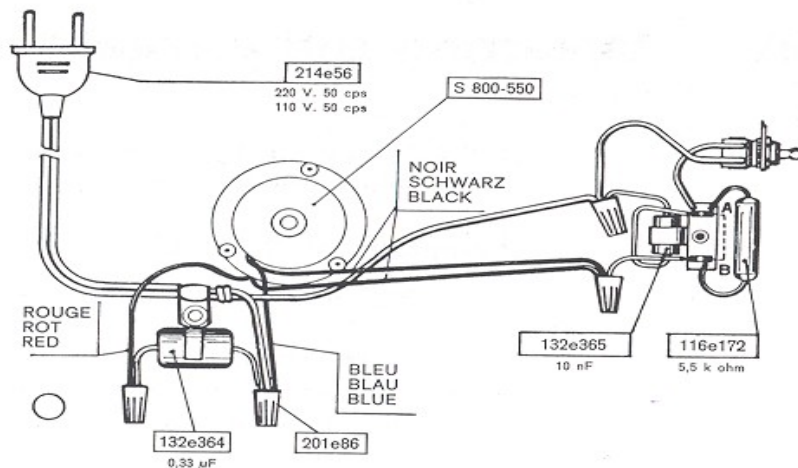

Fig. 5. Motor connections for 60 cycle 117 volt operation.

VI. Assembling the outer 12" turntable platter on the inner turntable

- ① Remove the stylus force calibration plate (part S 808-225), delivered with each TD-150 AB and A models, from the unit plate.
- ② Carefully centre the outer turntable platter on the inner platter and the rubber mat on top of them.
- ③ The central adapter (part S 800-522) is packed on the inner turntable. It may be installed in two inverse positions on the centre pin: for normal or for large hole records.

Important notice. The motor, its spindle and the motor pulley are engineered to very close tolerances. As a delicate and high precision instrument, it should be protected against any shock or strain when installing or forwarding the turntable. **Take particular care when removing or assembling the outer turntable on the inner turntable platter.**

Damages on these parts caused by accident will invalidate our warranty.

VII. Cartridge installation and connections

If a cartridge has been purchased which has been professionally premounted into the Thorens plug-in shell, disregard the following.

① Cartridge installation

The aluminium plug-in shell offers enough space and the necessary mounting hardware to suit any standard pick-up cartridge.

The specific mounting instructions furnished by the cartridge manufacturers should be followed EXCEPT that the screws delivered with the TD-150 AB and A turntables must be used. (The mount-

ing screws supplied with US cartridges are for US standards and will not fit the metric threads used on Thorens units.)

The cartridge height on the plug-in shell should be chosen in order to bring the stylus tip at a distance of $\frac{3}{4}$ " to $\frac{7}{8}$ " (19 to 22 mm) from the bottom of the shell. If necessary, make use of the furnished spacers.

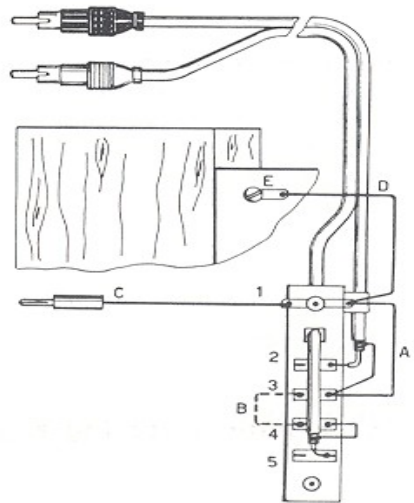

Fig. 6. Wiring diagram for pick-up output.

② Cartridge connections

Four separate colour coded leads are already soldered to the terminal pins in the shell:

Red — Right channel positive (hot)

Green — Right channel negative (shield)

These two leads constitute also the normal mono channel.

White — Left channel positive (hot)

Blue — Left channel negative (shield).

③ Pick-up output connections

The TD-150 AB and A models are wired at the factory according to Fig. 6.

Right channel: standard male phonoconnector plug, black colour.

Left channel: standard male phonoconnector plug, white colour.

Ground connection :

- The unit plate and the metal part of the arm are connected in **A** to the shield of the right channel cable acting as a ground lead.
- The shield of the left channel cable is insulated from the base plate of the turntable and from the metal parts of the arm.

The spring mounted parts of the turntable are connected to the fixed unit plate by ground lead D. Lug E should be fastened on the metal frame by the corresponding set screw of the pick-up wooden board.

If necessary for particular cartridges or amplifiers, two different wiring systems may be easily realized:

3 wire system

Connect lugs 3 and 4 on the terminal strip with a wire **B**; the shields of both channels are thus connected together and to the unit plate.

5 wire system

When the ground for the turntable cannot be returned to the amplifier ground through the signal carrying shieldings, the wire connecting lugs 1 and 3 should be cut at **A** and a separate insulated wire **C** connected from lug 1 to the common grounding point for the amplifiers.

④ Cartridge alignment

The new patented plug-in shell allows to adjust **first** the vertical tracking angle and then the stylus overhang for optimum tracking.

Vertical tracking angle

- a) Loosen slightly the two screws **A** on both sides of the shell and small screw **B** (see Fig. 7).
- b) Insert the shell plug in the arm socket, allowing the locating pin to enter the slot. Press inward and tighten the locking nut firmly, but not more than necessary. This operation is best performed when the arm is clamped in the arm rest.

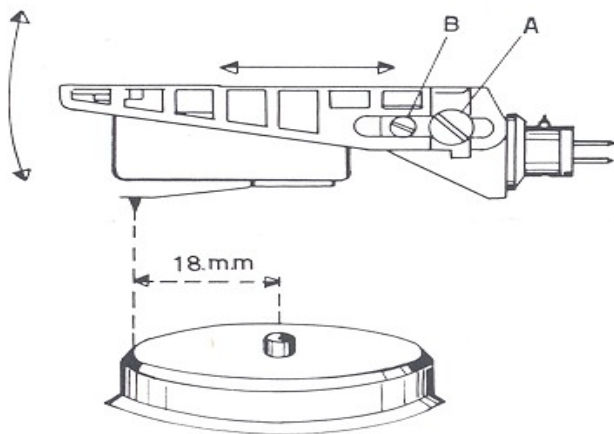

- c) Bring the arm over a record (caution: choose a worn record) and adjust the vertical tracking angle according to the instructions of the cartridge manufacturer. Make sure that the rear of the shell cannot contact a warped record. If necessary, increase the vertical distance between the stylus tip and the bottom of the shell with the help of spacers (see No. 1 above).
- d) Tighten small set screw B.

Fig. 7. Adjustment of plug-in shell.

Stylus overhang

For optimum tracking, the stylus overhang on the TP-13 pick-up arm should be 18 mm (45/64"). It is easily checked by making use of the centre adaptor (part S 800-522):

Place the adaptor on the centering pin in the position for large hole records and move the pick-up arm to this centering pin. The exact overhang is obtained when the stylus tip is just striking the upper circle of the adapter (see Fig. 7). Tighten the two screws A.

VIII. Pick-up arm adjustments

① Mounting the counterweight

As a precaution against damage in transit, the counterweight (part S 808-223) is packed separately in box D with its set knob A (S 808-211).

- a) Place the counterweight underneath the pick-up arm extension B, the sliding tube entering the corresponding hole on the counterweight (see Fig. 8).
- b) Turn set knob A counterclockwise until the counterweight may just be moved along the arm extension B.

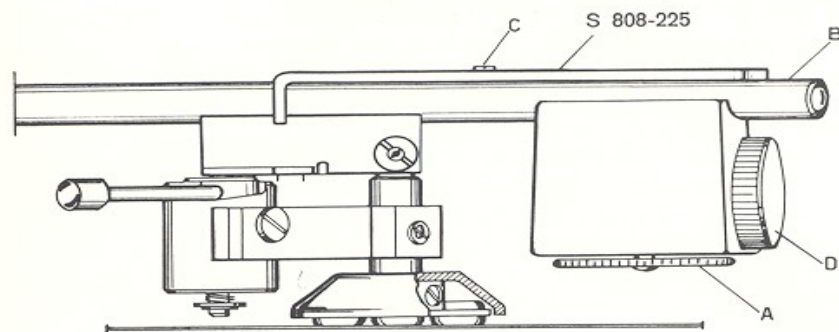

Fig. 8. Rear part of the pick-up arm.

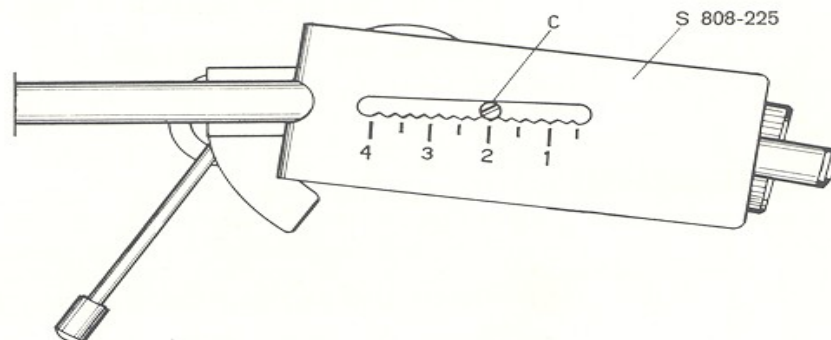

Fig. 9. Positioning the stylus force calibration plate.

② Balance and stylus force adjustment

The TP-13 integrated pick-up arm has been designed to reach an excellent longitudinal and lateral balance simultaneously to the adjustment of the stylus force for pick-up cartridges weighing between 5 and 19 grams. Proceed as follows:

- a) Place the stylus force calibration plate (part S 808-225) on top of the pick-up arm extension B according to Fig. 8 and 9, with pin C on the arm extension in the slot of the calibration plate. **Position the calibration plate with pin C in the indentation of the scale corresponding to the stylus force recommended by the cartridge manufacturer. Each indentation corresponds to 1/4 gram.**
- b) Position the arm so that the stylus tip is between the arm rest and the turntable platter. The arm control lever should be in the "play" position.

- c) Move the counterweight along the arm extension with the right hand (while maintaining the lateral position of the arm with the left hand to avoid damaging of the stylus) **until the arm assumes a horizontal position.**
If properly balanced, the arm will keep its position when slightly inclined above or below the horizontal.
The fine adjustment knob D may be turned to achieve a more precise balance.
- d) Remove the calibration plate.

Operation

- ① Place the record on the turntable.
- ② Push the " On-Off " knob down to start the turntable.
- ③ Turn the same knob to the desired speed.

Important notice: in order to protect the drive belt, the speed can only be changed when the turntable platter is revolving. The control knob cannot be turned whilst in the " Off " position.

- ④ Move the pick-up arm control lever to the " High " position.
- ⑤ Disengage the pick-up arm from its rest post (Caution: do not lift it by the plug-in shell) and move it just above the first non-modulated grooves of the record.
- ⑥ Gently move the pick-up arm control lever to the " Play " position. The viscous damped brake assures a smooth and precise landing on the record.

To stop the turntable :

- ⑦ Gently move the pick-up arm control to the " High " position.
- ⑧ Return the arm to the rest post.
- ⑨ Pull the " On-Off " knob to the " Off " position.

Maintenance

① Cleaning the belt and pulleys

For perfect functioning of the drive system of the TD-150 turntable, the belt, the motor pulley and the periphery of the inner turntable should be entirely free from any trace of oil or grease. If necessary, clean them with a clean rag impregnated with denatured alcohol.

See Fig. 10 for the correct position of the belt. The belt will be centred in the control fork only when the outer 12 " turntable platter is in position.

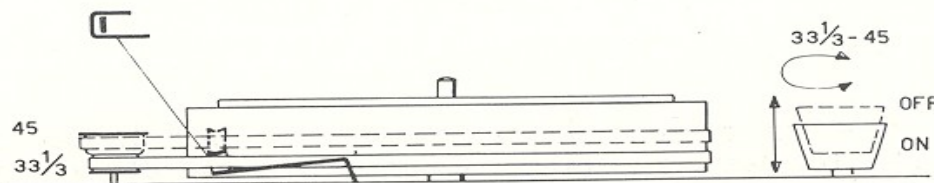

Fig. 10.

② Turntable spindle

The turntable spindle revolves on self-lubricating bushings and on a nylon thrust plate. Under normal conditions, lubrication is not necessary before several thousand hours running. Use exclusively Caltex or Texaco Regal Oil B (ROB), as supplied with our lubrication kit available as an accessory at your franchised dealer.

③ Motor

The slow speed double synchronous motor does not normally require any lubrication during its lifetime.

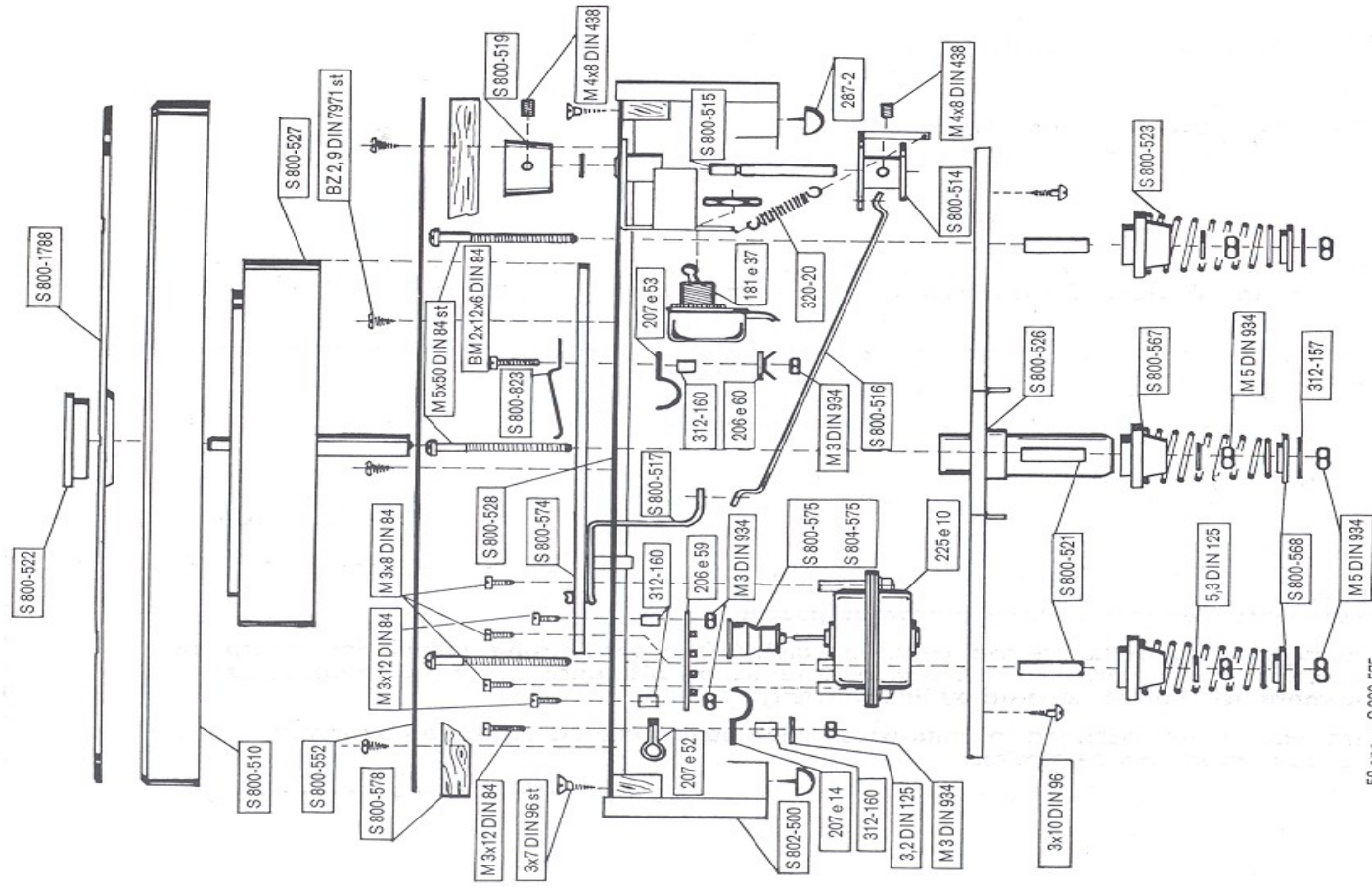

50 cps = S 800-575

60 cps = S 804-575

Our warranty

is granted under the following conditions:

1. Complete the information on the enclosed warranty card and return it within 10 days after purchase to the Thorens General Representative, the address of which will be given by our dealer.
2. **Before returning your turntable for inspection or repair**, write to the General Representative for permission to receive replacement part or to return the complete unit to the nearest authorized service station.
State Model number and Serial number of unit. Describe completely the defective operation and list the associated equipment.
3. After permission to return the unit is received, **pack it in the original carton according to the instructions of the manual**. Any pick-up arm, with the exception of the original Thorens Models specially designed for the TD-150 turntable, should be removed with their wooden mounting panel.
For Thorens pick-up arms, remove the counterweight and the plug-in shell, and pack them separately.
Shipment **MUST** be made shipping charges prepaid.
4. Any damage caused by failure to observe the instructions for packing, installation, operation and maintenance as contained in the manual furnished with each unit, by accident in transit or elsewhere, will not be covered by this warranty.
5. This warranty is not extended to units which have been repaired or altered by anyone other than an authorized service station.
6. The unit will be returned shipping charges collect. This warranty is in lieu of all others, expressed or implied.

THORENS

THORENS-FRANZ AG

CH 5430 Wettingen
Switzerland